

AUTO CAT™

Mid-Sized Automated Side Loader



"Nothing beats the speed and agility of the AutoCat!"

A mid-compact, mid-sized automated side loader ideal for select applications.

The AutoCat® is a unique, mid-size automated side loader designed to be highly effective in tackling special assignments. Highly maneuverable and fuel-efficient, the AutoCat can sweep through cul de sacs with ease, or chase down missed stops without wasting time. It's even small enough to handle narrow alleyways. AutoCat is the perfect addition to any fleet with larger, less nimble automated units.

Standard Features:

- 10 to 14 cu. yd. capacities
- arm reach of 6 ft.
- 8-10 second arm cycle time
- 600-800 lbs./yd. compaction

WAYNE®
ENGINEERED FOR PERFORMANCE

www.WayneUSA.com



10 yd³ AutoCat with satellite tailgate



14 yd³ AutoCat with rounded tailgate



Reaches 6 ft. with a fast arm

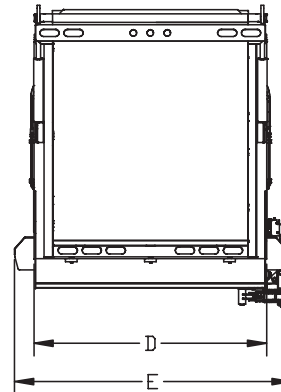
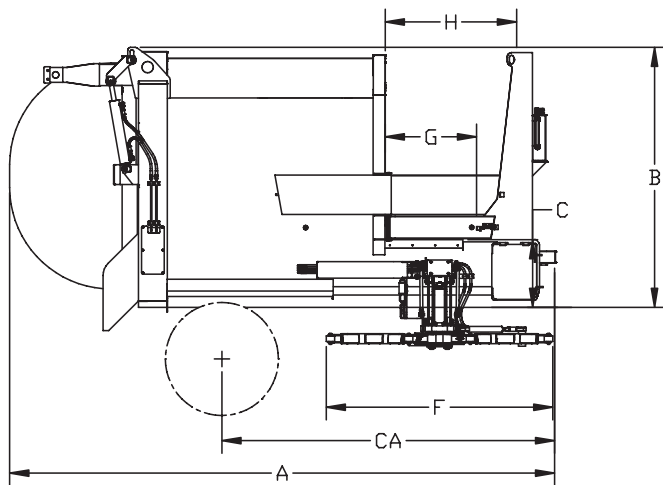

BODY SPECIFICATIONS

	10 cu. yd.	12 cu. yd.	14 cu. yd.
A Overall Length	166"	175"	192"
B Height Above Chassis Frame	92"	92"	92"
C Loading Sill Height Above Frame	24"	24"	24"
D Body Width	82"	82"	82"
E Overall Width	98"	98"	98"
F Arm Width	80"	80"	80"
G Loading Sill Width	31"	31"	31"
H Top of Hopper Opening Width	46"	46"	46"
CA Cab To Axle, Non Transfer	120"	120"	120"
CA Cab To Axle, Transfer	108"	108"	108"

LIFT ARM MECHANISM

Approx. Body Weight	7,100 lbs.	7,100 lbs.	7,100 lbs.
Truck GVWR Recommended	20,500 lbs.	23,000 lbs.	25,900 lbs.
Practical Filling Hopper Volume	1 cu. yd.	1 cu. yd.	1 cu. yd.
Dynamic Hopper Capacity (cu. yd./min)	3.5 cu. yd.	3.5 cu. yd.	3.5 cu. yd.
Arm Reach	72"		
Arm Lifting Capacity	250 lbs.		

Body Construction

- Sides – 11 gauge 50,000 PSI
- Top – 11 gauge 50,000 PSI
- Floor – 3/16" AR400 177,000 PSI

Hopper Construction

- Sides – 11 gauge 50,000 PSI
- Floor – 3/16" AR400
- Packer Face – 3/8" 50,000 PSI

Standard Features

- High strength, curved shell body design
- 10, 12 and 14 yard body capacity
- 6' arm reach
- 8-second arm cycle time
- Lifts container close to truck
- 17-second packing cycle time
- Dual-side clean-out doors
- 45° container dump angle
- Ultra-high strength AR400 floor

Hydraulic System

Cylinders – all double acting

- Gripper – (1) 1.75" dia.
- Arm Lift – (1) 3.00" dia.
- Pack – (2) 3" dia.
- Eject – (1) 3.5" dia.
- Tailgate Lift – (2) 2.5" dia.

Pump – Gear Type

- Capacity – 14 GPM body, 8 GPM arm
- Maximum operating pressure – 3,000 PSI

Hydraulic Tank

- Capacity – 25 gal.
- Location – upper front
- Sight Gauge – on tank
- Filter – 10 micron return line filter with by-pass valve

Optional Equipment

- Strobe lights
- Auto neutral arm control
- Work lights
- Rotating beacon

WAYNE®
ENGINEERED FOR PERFORMANCE

701 Performance Drive, Cedar Falls, IA 50613
Phone: (319) 266-1721 • Fax: (319) 266-8207

Tollfree: 888-66WAYNE
www.WayneUSA.com