

# PHOENIX™

Heavy-Duty Rear Loader



*"Heavy duty all the way through."*

## A high-compaction, heavy-duty rear loader ideal for all commercial routes.

The Phoenix combines a rugged body with a unique in-line packing design. Now 100% of tailgate packing forces are transferred directly to load compaction. The result is higher compaction ratings with greater load density distributed end to end. Add the automated, Arlock container handling system — you're ready to tackle every commercial route with unmatched speed and operator safety.

### Standard Features:

- 20 to 32 cu. yd. capacities
- 100% in-line directional packing
- ultra-high strength-to-weight ratio
- integrated resistance circuit for consistent packing
- rear camera (5" color LCD)
- trough-guided eject panel with liquid sump
- angled eject cylinder located above body floor
- 1000-plus lbs./yd. compaction rating



Arlock — the automated container handling option for safer, more productive commercial collections



Arlock shown with optional cart tipper

**WAYNE®**  
ENGINEERED FOR PERFORMANCE  
[www.WayneUSA.com](http://www.WayneUSA.com)

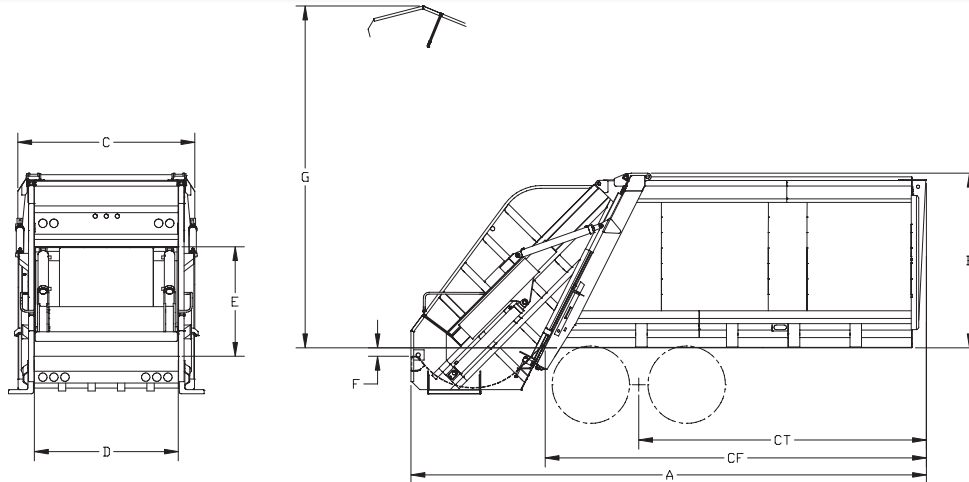

### BODY SPECIFICATIONS

|   | 20 cu. yd.      | 25 cu. yd. | 32 cu. yd. |
|---|-----------------|------------|------------|
| A: Overall Length                               | 244"            | 280"       | 324"       |
| B: Height Above Chassis Frame                   | 95"             | 95"        | 95"        |
| C: Body Width                                   | 96"             | 96"        | 96"        |
| D: Hopper Opening Width                         | 78"             | 78"        | 78"        |
| E: Hopper Opening Height                        | 68"             | 68"        | 68"        |
| F: Loading Sill Below Chassis Frame             | 4.6"            | 4.6"       | 4.6"       |
| G: Height Above Chassis Frame – Tailgate Raised | 182"            | 182"       | 182"       |
| CT: Cab to Tandem                               | 120"            | 156"       | 200"       |
| CF: Min. Usable CAT to End of Frame             | 171"            | 207"       | 251"       |
| Dynamic Hopper Capacity (cu. yd./min.)          | 6.5             | 6.5        | 6.5        |
| Volumetric Hopper Capacity                      | 3               | 3          | 3          |
| Volumetric Hopper Capacity w/CLD                | 3.3             | 3.3        | 3.3        |
| Approx. Body Weight                             | 14,700 lb.      | 15,300 lb. | 16,100 lb. |
| Truck GVWR Recommended                          | 52,000 lb.      | 58,000 lb. | 66,000 lb. |
| Pack Cycle Time                                 | 25 - 28 seconds |            |            |

### Features

- Curved shell body
- Auto back-pack
- Engine accelerator
- Reservoir sight gauge
- Chrome cylinder rods
- Access door (streetside)
- Rear camera system (5" color LCD)
- Backup alarm
- Driver alert buzzer (curbside)
- High-mount rear light bar
- Work lights
- LED ANSI/DOT lighting
- Mud flaps
- 12 mo. body/24 mo. cylinder warranty

### Hydraulic System

- Oil Reservoir — 50 gal.
- Oil Flow w/Standard Pump — 36 GPM
- Operating Pressure — 2,500 PSI
- Hose Burst Ratio — 4 to 1
- Return Filter — 10 micron
- Slide Cylinders — 5"
- Sweep Cylinders — 5"
- Eject Cylinder (20 yd.) — 5"
- Eject Cylinder (25 yd.) — 5 1/4"
- Tailgate Lift — 3 1/2"

### Body Construction

- Roof — 10 gauge GR80
- Sides — 10 gauge GR80
- Floor — 3/16" GR100
- Ejection Panel — 7 gauge GR50

### Hopper Construction

- Tailgate Upper — 12 gauge GR50
- Tailgate Lower — 3/16" GR100
- Tailgate Floor — 1/4" AR400
- Sweep Face — 1/4" AR400

### Options

- 12,000 lb. reeving winch
- 8,000 or 12,000 lb. overhead drum winch
- Hydraulically operated roll bar
- Single or dual cart tippers

**WAYNE®**  
ENGINEERED FOR PERFORMANCE

701 Performance Drive, Cedar Falls, IA 50613  
Phone: (319) 266-1721 • Fax: (319) 266-8207

Tollfree: 888-66WAYNE  
[www.WayneUSA.com](http://www.WayneUSA.com)